

- EXCELENTE OXIGENAÇÃO E INCORPORAÇÃO DE ÁGUA NA MASSA (55-100%); 0-8H**
 Excellent oxygenation and water absorption in the dough (55-100%); 0-8h / Excelente oxigenación y incorporación de agua en la masa (55-100%); 0-8h / Excellente oxygénation et incorporation d'eau dans la pâte (55-100%); 0-8h / Hervorragende Sauerstoffzufuhr und Wasseraufnahme im Teig (55-100%); 0-8h
- PERMITE AMASSAR 5% DA CAPACIDADE TOTAL DA TINA**
 Allows 5% of the total bowl capacity to be kneaded / Permite amasar 5% de la capacidad total de la artesa / Permet de pétrir 5% de la capacité totale du pétrin / Ermöglicht das Kneten von 5% der Gesamtkapazität des Kessels
- GANCHO E TINA COM MOTORES DE 2 VELOCIDADES SINCRONIZADAS**
 Hook and bowl with motor of 2 speeds perfectly synchronised / Gancho y artesa con motores de 2 velocidades sincronizadas / Cuve et crochet avec moteurs de 2 vitesses synchronisées / Haken und Wanne mit synchronisierten 2-Gang Motoren
- PROGRAMAÇÃO DE RECEITAS EM COMANDO DIGITAL E TÁTIL**
 Programmable recipes on digital and touchscreen control panels / Programación de recetas en mandos digital y táctil / Programmation de recettes en commande digitale et tactile / Rezeptprogrammierung mit Digital- und Touchscreen-Steuerung
- TRANSMISSÃO MECÂNICA SILENCIOSA DE REDUZIDA MANUTENÇÃO (CORREIAS PERFIL "V")**
 Silent and efficient mechanic transmission (through "V" belts) / Transmisión mecánica silenciosa y eficiente (correas dentadas perfil "V") / Transmission mécanique silencieuse de réduite maintenance (courroies profil "V") / Geräuscharmes mechanisches Getriebe mit geringem Wartungsbedarf (Schmalkeilriemen)
- PÉS EM AÇO INOXIDÁVEL AISI 304**
 Feet in AISI 304 stainless steel / Pies en acero inoxidable AISI 304 / Pieds en acier inoxydable AISI 304 / Füße aus rostfreiem AISI 304 Stahl
- DRENO NA TINA**
 Drain cap / Desagüe en la artesa / Cuve avec bouchon / Ablassstopfen



AEF
F / SERIE



**Reward
Hospitality**

Contact our team for enquiries.
 Commercial: 0800 428 733 | Domestic Products: 0800 697 465 | Service: 0800 178 349
www.rewardhospitality.co.nz

AMASSADEIRA ESPIRAL
 SPIRAL MIXER / AMASADORA ESPIRAL / PÉTRIN À SPIRALE / SPIRALKNETER



[standard]

[inox]

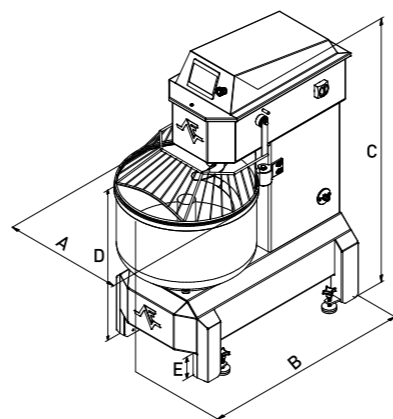

OC_003-14		AEF012	AEF030	AEF050	AEF080	AEF100	
CAPACIDADE DE FARINHA (kg)-(lb) * Flour capacity / Capacidad harina / Capacité farine / Mehlfassungsvermögen	MIN.	0,60 (1,32)	1,50 (3,30)	2,50 (5,51)	4 (8,82)	5 (11,02)	
	MAX.	12 (26,46)	30 (66,14)	50 (110,23)	80 (176,37)	100 (220,46)	
VOLUME DO TINA (l) Bowl volume / Volumen artesa / Volume cuve / Kesselvolumen		29	73	112	189	250	
POTÊNCIA MOTOR ESPIRAL (kW)-(hp) Power of spiral motor / Potencia motor de la espiral / Puissance du moteur de spirale / Leistung Spirale Motor	1	230V-1ph-50/60Hz	1,5 (2)	-	-	-	-
		230V-3ph-60Hz	-	-	3,3 (4,4)	-	-
		230V-3ph-50/60Hz	0,55 (0,75)	1,5 (2)	-	5,5 (7,5)	5,5 (7,5)
		400V-3ph-50Hz	-	-	1,9 (2,5)	-	-
		400V-3ph-50/60Hz	0,55 (0,75)	1,5 (2)	-	5,5 (7,5)	5,5 (7,5)
	400V-3ph-60Hz	-	-	3,3 (4,4)	-	-	
	2	230V-1ph-50/60Hz	1,5 (2,0)	-	-	-	-
		230V-3ph-60Hz	-	-	5,5 (7,5)	-	-
		230V-3ph-50/60Hz	2,2 (3)	2,5 (3,4)	-	8 (10,7)	8 (10,7)
		400V-3ph-50Hz	-	-	3,7 (5)	-	-
400V-3ph-50/60Hz		2,2 (3)	2,5 (3,4)	-	8 (10,7)	8 (10,7)	
400V-3ph-60Hz	-	-	5,5 (7,5)	-	-		
POTÊNCIA MOTOR TINA (kW)-(hp) Power of bowl motor / Potencia motor de la artesa / Puissance du moteur de la cuve / Leistung Kessel Motor	1	230V-1ph-50/60Hz	-	-	-	-	
		230V-3ph-60Hz	-	-	0,3 (0,4)	-	-
		230V-3ph-50/60Hz	-	0,3 (0,4)	-	0,55 (0,75)	0,55 (0,75)
		400V-3ph-50Hz	-	-	0,3 (0,4)	-	-
		400V-3ph-50/60Hz	-	0,3 (0,4)	-	0,55 (0,75)	0,55 (0,75)
	400V-3ph-60Hz	-	-	0,3 (0,4)	-	-	
	2	230V-1ph-50/60Hz	-	-	-	-	-
		230V-3ph-60Hz	-	-	1,2 (1,6)	-	-
		230V-3ph-50/60Hz	-	1,2 (1,6)	-	2,2 (3)	2,2 (3)
		400V-3ph-50Hz	-	-	1,2 (1,6)	-	-
400V-3ph-50/60Hz		-	1,2 (1,6)	-	2,2 (3)	2,2 (3)	
400V-3ph-60Hz	-	-	1,2 (1,6)	-	-		
PESO LÍQUIDO (kg)-(lb) Net weight / Peso neto / Poids net / Nettogewicht		188 (414,46)	343 (756,18)	493 (1086,87)	723 (1593,93)	747 (1646,84)	
DIMENSÕES (mm)-(in) Dimensions / Dimensiones / Dimensions / Dimensionen	A	475 (18 11/16)	570 (22 7/16)	675 (26 9/16)	786 (30 15/16)	870 (34 1/4)	
	B	740 (29 1/8)	1045 (41 1/8)	1200 (47 1/4)	1485 (58 7/16)	1567 (61 11/16)	
	C	1082 (42 5/8)	1263 (49 3/4)	1450 (57 1/16)	1510 (59 7/16)	1510 (59 7/16)	
	C	1103 (43 7/16)	1284 (50 9/16)	1448 (57)	1531 (60 1/4)	1531 (60 1/4)	
	D	682 (26 7/8)	782 (30 13/16)	850 (33 7/16)	880 (34 5/8)	920 (36 1/4)	
E	100 (3 15/16)	100 (3 15/16)	100 (3 15/16)	100 (3 15/16)	100 (3 15/16)		

*Baseado em: 60% de hidratação da massa, 12% humidade da farinha, 2°C água / Based on: 60% dough hydration, 12% flour moisture, 2°C water / Basado en: 60% hidratación de la masa, 12% humedad de la harina, 2°C agua / Basé en: 60% hydratation de la pâte, 12% Humidité de la farine, 2°C eau / Beruhend auf: 60% Teig Hydratation, 12% Mehlfeuchtigkeit, 2°C Wasser; Cota para máquina com opção comando tátil / Dimension for machine with touchscreen option / Medida para máquina con opción de pantalla táctil / Dimension de la machine avec écran tactile / Maß für Maschine mit Touch-Screen als Option.

OC_003-12		AEF012	AEF030	AEF050	AEF080	AEF100	
[s]	[i]	[s]	[i]	[s]	[i]	[s]	[i]
ESTRUTURA ELEVADA EM RELAÇÃO AO PISO Machine frame lifted towards the floor / Estructura elevada referente al suelo / Structure élevé en relation au sole / Hohes Gestell		✓	✓	✓	✓	✓	✓
COMANDO DIGITAL Digital control / Mandos digitales / Commande digitale / Digitalsteuerung		✓	✓	✓	✓	✓	✓
COMANDO ANALÓGICO Analog control / Mandos analógicos / Commande electromécanique / Analogsteuerung		○	○	○	○	○	○
COMANDO TÁTIL Touchscreen / Pantalla táctil / Écran tactile / Touchscreen		○	○	○	○	○	○
CONVERSOR DE FREQUÊNCIA (1ph) - 2 VELOCIDADES Inverter (1ph) - 2 speeds / Variador de frecuencia (1ph) - 2 vel / Variateur de vitesses (1ph) - 2 vit / Frequenzrichter (1ph) - 2 geschw		○	○	□	□	□	□
CONVERSOR DE FREQUÊNCIA (3PH) - 2 VEL. Inverter (3ph) - 2 speeds / Variador de frecuencia (3ph) - 2 vel / Variateur de vitesses (3ph) - 2 vit / Frequenzrichter (3ph) - 2 geschw		○	○	□	□	□	□
CONVERSOR DE FREQUÊNCIA (multispeed) Inverter (multispeed) / Variador de frecuencia (multispeed) / Variateur de vitesses (multispeed) / Frequenzrichter (multispeed)		□	□	□	□	□	□
DRENO Drain cap / Desagüe / Bouchon / Ablassstopfen		✓	✓	✓	✓	✓	✓
GRELHA DE SEGURANÇA Security Cover / Cobertura de seguridad / Couvercle de protection / Geschlossene Staubabdeckung		✓	✓	✓	✓	✓	✓
TAMPA FECHADA EM AÇO INOXIDÁVEL Closed security cover built in stainless steel / Tapa cerrada en acero inoxidable / Couvercle de protection en acier inoxydable / Geschlossenes Sicherheitsgitter aus Edelstahl		○	○	○	○	○	○
TAMPA DE SEGURANÇA EM POLÍMERO TÉCNICO Security cover in technical polymer / Tapa de seguridad en polímero técnico / Couvercle de protection en polymère technique / Geschlossenes Sicherheitsgitter aus Polyäthylen		□	□	□	□	□	□
RASPADOR, PÁ Scraper, Paddle / Rascador, Pala / Racleur, Palette / Kesselabstreifer, Flachrührer		□	□	□	□	□	□
INVERSÃO DE TINA Bowl reversal / Inversor de artesa / Marche arrière / Kesseldrehung		□	□	✓	✓	✓	✓
DOSEADOR DE ÁGUA - COMANDO DIGITAL Water meter - Digital control panel - Mandos digitales / Cuentalitros - Commande digitale / Doseur d'eau - Commande digitale / Wasser Dosiergeräte - Digitalsteuerung		□	□	○	○	○	○
DOSEADOR DE ÁGUA - COMANDO ANALÓGICO Water meter - Analog control / Cuentalitros - Mandos analógicos / Doseur d'eau - Commande electromécanique / Wasser Dosiergeräte - Analogsteuerung		□	□	□	□	□	□
DOSEADOR DE ÁGUA - COMANDO TÁTIL Water meter - Touchscreen / Cuentalitros - Pantalla táctil / Doseur d'eau - Écran tactile / Wasser Dosiergeräte - Touchscreen		□	□	○	○	○	○

[standard] estrutura em aço carbono pintada / white painted carbon steel frame / estructura en acero carbono pintada en blanco / bâti en acier au carbone /
Konstruktion in unlegiertem lackierten Stahl in weiß lackiert; [inox] estrutura em aço inoxidável AISI 304 / stainless steel AISI 304 frame / estructura en acero
inoxidable AISI 304 / bâti en acier inoxydable AISI 304 / Konstruktion in Edelstahl AISI 304.

✓ Equipamento de Série / Standard-production Equipment / Equipamiento de Serie / Équipement de Série / Serienausstattung; ○ Opção / Option / Opción / Option /
Option □ Sob consulta / By request / Bajo consulta / Sur demande / Nach Anfrage □ Não aplicável / Not applicable / No applicable / Non applicable / nicht anwendbar.